

Please keep the product invoice and this document for warranty.

# Warranty Certificate

Username/Title:	
Phone Number:	Address:
Installation date:	Invoice Number and Date:
Product Description: Genos Parking Air Conditioner NRM-02 Serial Number :	Vehicle Plate Number:
Vehicle Model and Year:	
User Signature:	Dealer/Service Stamp and Signature:

## Warranty Statement

The product is under warranty for 2 years against malfunctions caused by the manufacturer's design or production errors. For full warranty terms, please visit our company's website.

Damages caused by installations made outside our authorized services, disassembly of the product, tearing of labels or improper use are not covered by the warranty. The invoice and warranty document must be presented during the warranty period. If the invoice and warranty document cannot be presented or if the documents are tampered with, the product is out of warranty.

## Statement of Responsibility

The user must pay attention to safety during the installation of the product on the vehicle. In case of any personal safety problem, the user is responsible.

# GENOS®

## NRM-02 SINGLE FAN PARKING AIR CONDITIONER

# User Manual

Thank you for choosing our product. Please read this manual carefully before using the parking air conditioner. Before using the parking air conditioner, you can achieve better performance by quickly cooling your vehicle's original air conditioner. This parking air conditioner is designed for use when the vehicle is parked. However, our product is also suitable for use while the vehicle is running and driving.

**İTHALATÇI**  
Norm Elektronik Sanayi ve Dış Ticaret A.Ş.  
ATB İş Merkezi, G Blok, No: 189-190, 06105  
Macunköy- Yenimahalle/ ANKARA  
Tel: +90 312 397 79 95 (pbx)  
www.normelektronik.net

Powered by **NORM** electronics

## Fault-Warning Definitions

Error Code	Definition	Explanation
E1	Low or high voltage protection	Battery voltage outside set low or high protection levels
EC	Sensor Error	Short circuit in sensor line, poor contact or sensor error
EF	Evaporator Fan is faulty	Evaporator fan cable is broken, fan is blocked or fan motor is faulty
E2	Overcurrent protection is active	Air conditioner gas is too much, condenser is dirty or blocked or condenser fan is faulty
E3	System lock is enabled	Compressor wiring fault and/or compressor blocked
E4	Control panel low voltage protection is enabled	Malfunction in control panel power supply circuit and/or control board
E5	Short circuit in phase line	Short circuit, breakage or wear in compressor cables
E6	Control panel high voltage protection is activated	Malfunction in power supply circuit and/or control panel circuit
E7	Interruption in compressor operation	Contact problem in the compressor cable and/or compressor failure
F8	Condenser fan failure	Condenser fan cable broken, fan blocked or fan motor faulty
H0	Over temperature protection	Air conditioner gas pressure is high, condenser is dirty or clogged, or condenser fan is faulty.
H2	Compressor phase protection is active	Poor contact, short circuit or fault in compressor control circuit in compressor/control panel cable

## Product Image - Outdoor Unit

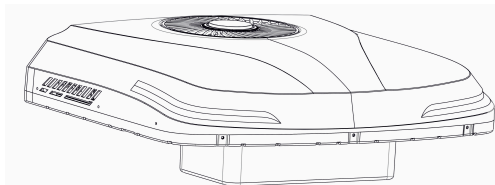

## Technical Specifications

Air Circulation Volume	450 m3/h	
Working Voltage	24V	12V
Power Consumption	750 W	740 W
Cooling Capacity	2200 W	1800 W
Current (at 35°C outdoor temperature)	9-29A	20-55A
Compressor Type	Twin rotor	Scroll
Evaporator and Condenser Fan Motors	Fırçasız	Fırçasız
Energy Efficiency Ratio (EEP)	2.71 W/W	
Air conditioning gas R134a Filling Quantity	550±5 g	
Control Mode	Smart Frequency Converter	
Set Temperature Adjustment Range	17-30 °C	
Plastic Material	ABS	
Noise Level	37 dB	
Size (length X width X height)	860*750*160 mm	
Weight	27 kg	
Outdoor Unit Color	White	

## Digital Control Panel

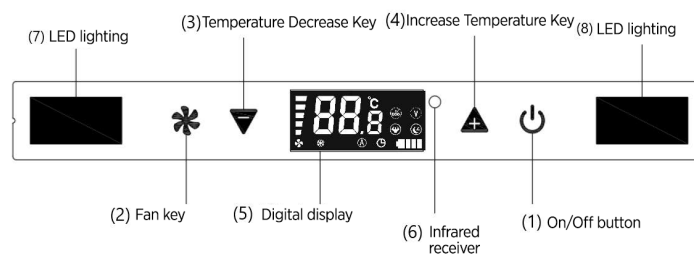

- (1) On/Off Button: Turns the parking air conditioning on and off.
- (2) Fan Button: Increases the air blowing intensity in 1st, 2nd, 3rd, 4th and 5th levels respectively. If pressed at level 5, the fan intensity continues from level 1.
- (3) Temperature Decrease Key: Decreases the set (target) temperature.
- (4) Increase Temperature Key: Increases the set (target) temperature.
- (5) Display: Shows set temperature, internal temperature, battery voltage, error codes and operating mode icon.
- (6) Infrared receiver: Detects remote control signals.
- (7) LED lights are turned on and off with a remote control.

## Low voltage protection function

Your parking air conditioner has a low voltage protection feature. The purpose of this function is to prevent your battery from running out while the air conditioner is running. Your air conditioner comes with this function installed and set at the factory. However, if you want to change the low voltage protection function settings, you should ask for support from our authorized services.

## Voltage Display

If the VOLTAGE button on the remote control is pressed while the air conditioner is on, the battery voltage will be displayed on the control panel display together with the red V icon. After 5 seconds, the V icon disappears and the display returns to the previous mode.

## Remote Control

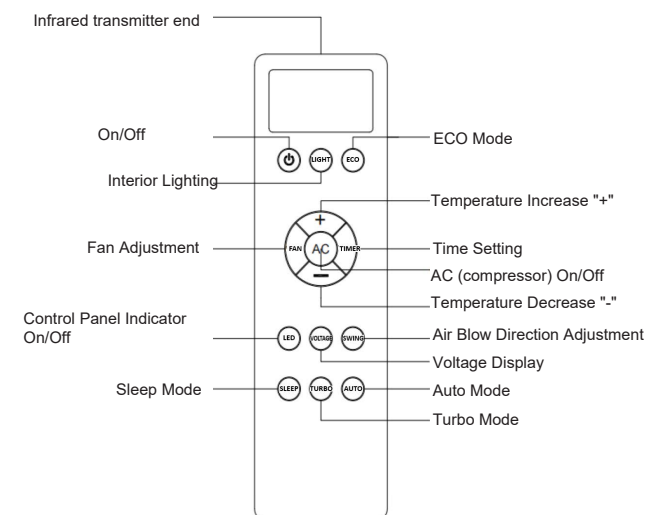

## Warnings

If there are curtains, doors or other objects that block the remote control from sending a signal to the air conditioner, the air conditioner will not be controlled by the remote control.

The remote control should not come into contact with liquids. Do not expose the remote control to direct sunlight or place it in an excessively hot place.

If other electronic devices are affecting the remote control negatively, please move your remote control away from these devices.

When the battery of the remote control is worn out, replace it with a new one, do not use old battery or different type of battery, otherwise it will cause the remote control failure.

If you do not use the remote control for a long time, please remove the battery, otherwise the battery discharge will damage the remote control.

If the remote control screen displays a low battery warning, the remote control batteries need to be replaced. The average battery life is approximately one year.

The effective distance of the remote control is 8 meters. The infrared signal transmitter end of the remote control should be pointed towards the control

# Remote Control Functions

## Quick Start

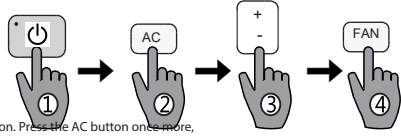

- 1 Press the On/Off button.
- 2 Press the AC button to turn on the cooling function. Press the AC button once more, the device will exit the cooling mode and switch to the fan mode.
- 3 While the cooling is on, set the desired SET temperature with the "+" and "-" buttons in the middle of the remote control. The SET temperature can be set between 17°C and 30°C. If the indoor temperature drops below the SET temperature, the cooling will be turned off.
- 4 While the cooling is on or only the fan is running, the 5-stage blowing level can be set with the FAN button. The higher the fan level selected, the louder the cooler will be. Please select a comfortable fan level for yourself.
- 5 You can turn off the device by pressing the on/off button while the air conditioner is running.

## Timing Setting

- 1 With the timing feature, you can set the number of hours after which the air conditioner will turn off. 
- 2 On Time Setting: While the air conditioner is off, press the TIMER button on the remote control. Then, by pressing the TIMER button one by one or continuously, the air conditioner on time can be set between 0 and 24 hours. The set time value is displayed on the LCD screen of the remote control.
- 3 Off Time Setting: While the air conditioner is on, press the TIMER button on the remote control. Then, by pressing the TIMER button one by one or continuously, the air conditioner off time can be set between 0 and 24 hours.
- 4 To cancel the on or off timing setting, the hour value must be changed to zero with the TIMER button.

## Air Blow Direction Adjustment

After turning on the air conditioner, press the SWING button and the air blowing flap will automatically move forward and backward. You can stop the blowing flap by pressing the SWING button again in the desired blowing direction. The angle of the blowing flap should not be adjusted too narrow. Otherwise, cooling may be adversely affected due to the air outlet being too narrow, and water drops may form on the surface of the blowing flap as a result of moisture condensation.

SWING

TURBO

## Turbo Mode

While the parking air conditioner is on and the cooler is on, TURBO mode is started for rapid cooling by pressing the TURBO button on the remote control. In TURBO mode, the system will set the SET temperature to 17°C and the fan speed to the 5th stage. TURBO mode is exited by pressing the TURBO button again and the air conditioner returns to the last operating mode. If the user does not exit TURBO mode by himself, the air conditioner will automatically exit TURBO mode 40 minutes after starting TURBO mode and will continue cooling with the 4th stage fan and 22°C SET temperature. The user can restart TURBO mode by pressing the TURBO button again. However, since staying in TURBO mode persistently will cause the device to draw high current, it is recommended to check the battery charge level before switching back to TURBO mode.

LIGHT

## Interior Lighting

By pressing the LIGHT button on the remote control, you can turn the LED lighting on the indoor unit on or off.

## Digital Display

When the air conditioner is turned on, the SET temperature is displayed on the digital control panel display. To prevent the digital control panel display illumination from negatively affecting sleep at night, press the LED button. The display illumination will turn off. When the LED button is pressed again, the digital control panel display will light up. In fan mode, the current indoor temperature value is displayed on the control panel display.

LED

## Sleep Mode

When the air conditioner is turned on, the sleep mode is entered by pressing the SLEEP button on the remote control. When the sleep mode is entered, the device will set the SET temperature to 24°C and the fan speed will be reduced to the 2nd stage. In sleep mode, the user can increase the fan level to the 2nd stage at most.

SLEEP

## ECO Mode

To switch to ECO mode, press the ECO button even when the device is off. In ECO mode, the air conditioner automatically sets the SET temperature to 26°C. After 8 hours, it will automatically exit ECO mode and switch to normal cooling mode. It is not recommended to use the 26°C energy saving (ECO) mode when the outdoor temperature is very high.

ECO

## Auto Mode

When the parking air conditioner is on, the automatic mode is started by pressing the AUTO button on the remote control. In automatic mode, the fan blowing level is automatically determined according to the difference between the interior temperature and the SET temperature. As the interior temperature of the vehicle approaches the SET temperature value, the fan blowing speed decreases. In ECO mode dışındaki tüm çalışma modlarında AC kompresörün devir hızı, iç sıcaklık ve SET sıcaklığı arasındaki farka göre otomatik olarak değişir. İç ortam sıcaklığı SET değerine yaklaştıkça kompresör devri ve aküden çekilen akım azalır.

AUTO

## Replacing Remote Control Batteries

- The remote control is powered by two AAA batteries.
- Open the battery cover.
- Insert two new batteries, paying attention to the "+" and "-" signs in the battery compartment.
- Close the cover.

# Assembly Summary

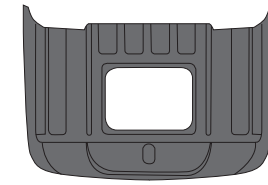

- 1 Clean the area around the sunroof window on top of the vehicle.

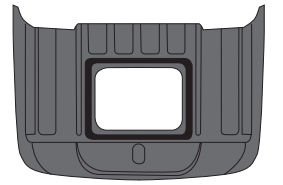

- 2 Paste the sealing sponge around the sunroof window

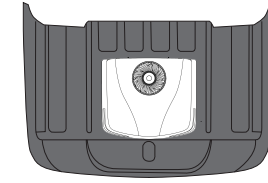

- 3 Place the outdoor air conditioning unit inside the window

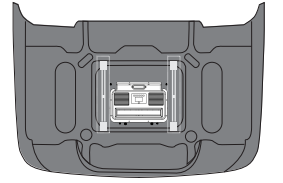

- 4 Connect metal connecting rods

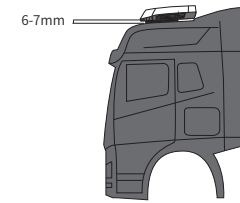

- 5 After installation, the thickness of the sealing insulation sponge should be 6-7 mm.

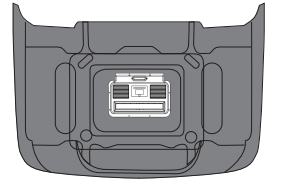

- 6 Mount the mounting frame on the indoor unit

Powered by **NORMA** glactronics